

MF / Cessna 152

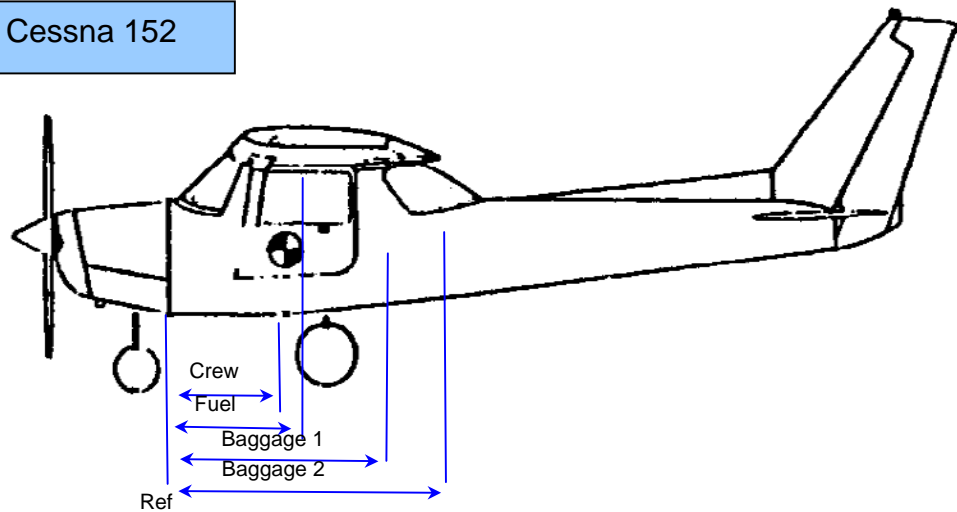

Bezeichnung	Masse	x Arm	= Moment
Leermasse / Empty Weight	533,00	x 0,77 m	412,34 kgm
Crew		x 0,99 m	
Kraftstoff (93) L: <input type="text"/> x 0,72 kg =		x 1,02 m	
Gepäckbereich 1 (max 54 kg / 1+2 max 54 kg)		x 1,63 m	
Gepäckbereich 2 (max 18 kg / 1+2 max 54 kg)		x 2,13 m	
Startmasse / TOW (MTOW 758 kg)		XXXXX	

